

LUXOR | H. WILSON



2015-2016
FULL LINE CATALOG



Table of Contents

■ Marker Boards	4-9	■ Utility Cabinets	54-57
■ Flat Panel TV Carts	10-19	■ Automotive Carts	58-59
■ Charging Carts	20-23	■ Janitorial Carts	60
■ Presentation Stations	24-44	■ Plastic Utility Carts	61-69
■ Workstations + Desks	45-50	■ Steel Carts	70-73
■ Book Trucks + Podiums	51	■ Index	74-75
■ Serving Carts	52-53		



Most Luxor | H. Wilson products are covered by a manufacturer's limited lifetime warranty against defects and workmanship. Visit www.luxorfurn.com/warranty for full details. Many of our products are made in the USA and feature recycled material. All products ship via FedEx or UPS unless marked with this truck line icon: 

MADE IN USA

NEW



LUXOR | H. WILSON RETAIL PROGRAM

We are launching a brand new initiative to expand into the retail market. With a combination of outstanding product quality and affordable price points we believe a wide range of our product line would be a perfect fit for sale at retail. Contact us for more details. Call **1-800-323-4656** or e-mail us at sales@luxorfurn.com to become a Luxor | H. Wilson Dealer.



New Products



6



65

- Black Marker Boards
- Glass boards
- Flat Panel TV Carts
- Charging Carts
- Stand Up Desks
- Utility Carts



11



4



22



5



46



7

NEW

Introducing new and improved 4" stem casters to replace the current industrial 4" casters. These sleek casters are non-marring, have improved ball bearings and feature a more modern look.

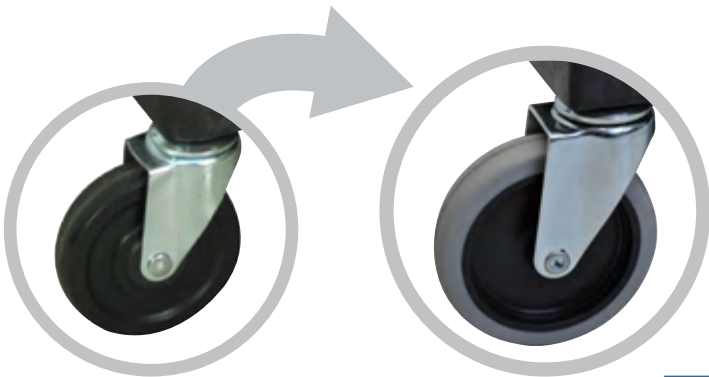

Marker Boards

Glass



- Tempered 1/4" (6mm) thick glass
- Frosted white glass finish is the ideal surface for wet erase markers
- Will not stain or ghost
- Stainless steel mounting pucks
- Multiple configurations to chose from



NEW



WGB4030
40"W x 30"H



WGB4836
48 $\frac{1}{2}$ "W x 35 $\frac{1}{2}$ "H

Marker Boards

Glass



NEW

- The lock and pivot system allows the glass to tilt up to 8° in each direction
- Tempered 5/16" (8mm) thick glass
- Lifetime warranty
- Features new non-marring grip swivel casters with locking brake



MGB3040
Board Size: 30"W x 40"H
Assembled: 35"W x 24"D x 68"H



MGB4836
Board Size: 47³/₈"W x 35³/₈"H
Assembled: 52¹/₂"W x 24"D x 66"H

Marker Boards

Black Boards



BW4836M
47¼"W x 35½"H

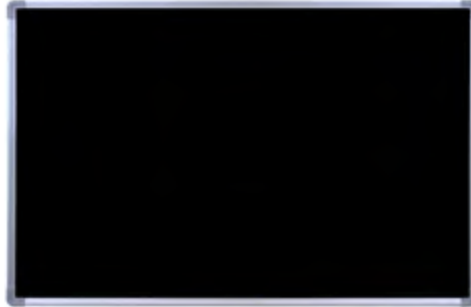

BW4030M
40"W x 30"H

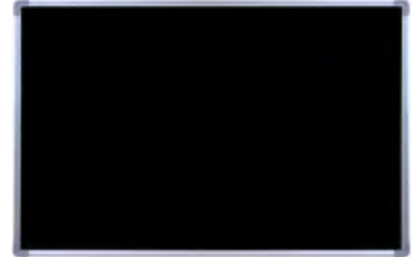

BW3624M
36"W x 24"H

- Gloss black magnetic surface
- Aluminum frame around board
- Mounting hardware included
- All black boards have a 10 year warranty
- Easily wipes clean using soft cloth and glass cleaner



All black boards include a set of 4 wet erase neon markers. (colors may vary).



Marker Boards

Black Boards



BM3648M

Board Size: 36"W x 48"H
Assembled: 74½"W x 23"D x 72"H



BM3040M

Board Size: 30"W x 40"H
Assembled: 35½"W x 20½"D x 68"H

NEW

All black boards include a set of 4 wet erase neon markers. (colors may vary).

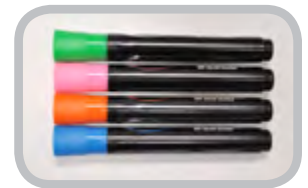

- Spring release system allows the board to rotate and lock with ease
- Two sided gloss black magnetic surface
- Aluminum frame around board
- All black boards have a 10 year warranty
- Two inch casters two with locking brake
- Knob adjustment locks board in place



Marker Boards

Whiteboards



*Also available in Whiteboard / Chalkboard configurations.

MB7240 | MB4836 | MB3624



MB7240WW*

Board Size: 72"W x 40"H
Assembled: 74½"W x 23"D x 69"H



MB4836WW*

Board Size: 48"W x 36"H
Assembled: 51½"W x 20½"D x 65½"H



MB3624WW*

Board Size: 36"W x 24"H
Assembled: 39"W x 20½"D x 53½"H

- Reversible whiteboard on both sides (MBWW series) or whiteboard/ chalkboard (MB series) both sides are magnetic.
- Whiteboards are painted steel with an aluminum frame
- 4 Furniture casters for easy mobility
- All whiteboards have a 10 year warranty
- Includes marker/eraser tray

PB3040W Features:

- Folds up for easy transport
- Paper holder on top edge
- Adjust in height from 45"-68½"
- Legs lock securely into place



MB3648WW

Board Size: 36"W x 48"H
Assembled: 41¾"W x 20½"D x 72"H



MB3040WW

Board Size: 30"W x 40"H
Assembled: 35¾"W x 20½"D x 68"H



L270

Board Size: 24"W x 36"H
Assembled: 27"W x 20½"D x 59"H

NEW



PB3040W

Board Size: 27½"W x 39¾"H
Assembled: 30½"W x 18"D x 45" - 68½"H



WB7240W
Board Size: 72"W x 40"H



WB4836W
Board Size: 48"W x 36"H



WB3624W
Board Size: 36"W x 24"H

- Aluminum frame around painted steel marker board
- All whiteboards have a 10 year warranty
- Magnetic writing surface
- Includes marker/eraser tray

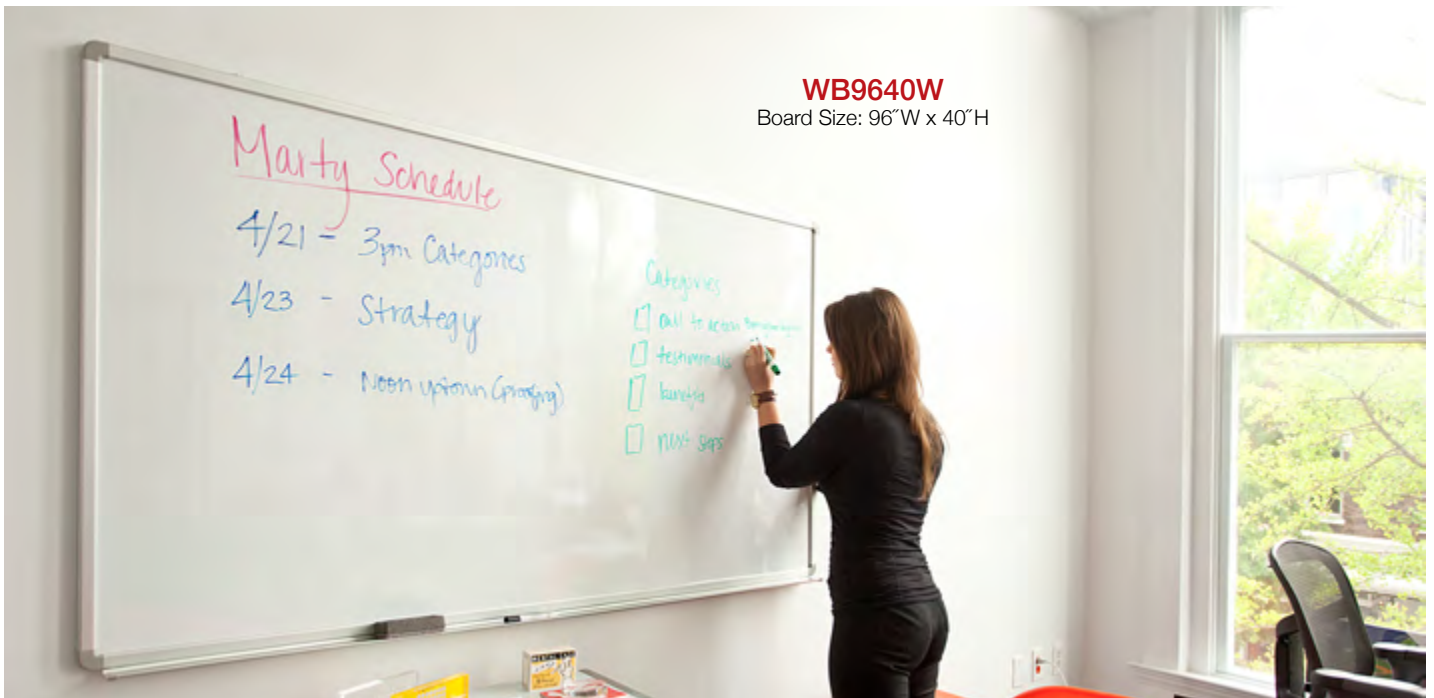

WB9640W
Board Size: 96"W x 40"H

Flat Panel TV Carts

FP Series



FP2000
Base Model

FP2000 Features:

- Designed for 32" - 60" flat panel TV
- Weight capacity 100 lbs.
- VESA compliance 200 x 200mm, 200 x 400mm, 300 x 300mm, 400 x 400mm, 400 x 600mm
- Seamless pipes with powder coat paint finish
- Cable management holes through main column
- All casters have locking brake
- Locking mechanism included (padlock sold separately)
- Measures 32 $\frac{3}{4}$ " W x 46 $\frac{1}{2}$ " - 62 $\frac{1}{2}$ " H (from floor to the top of the poles)
- Adjustable in 2" increments

FP2750 Features:

- Includes all FP2000 features
- Accessory shelf: 19 $\frac{5}{8}$ " W x 12 $\frac{1}{2}$ " D, (11 $\frac{3}{8}$ usable depth space)
- Accessory shelf weight capacity: 25 lbs.
- Camera Mount: 10" W x 5" D
- Camera Mount shelf weight capacity: 10 lbs.

NEW



Locking mechanism included in all models (actual padlock sold separately).



All Models include a cable management system through the adjustable poles.



FP2750
With Accessory Shelf
And Camera Mount



FP2500
With Accessory Shelf

FP2500 Features:

- Includes all FP2000 features
- Accessory shelf: 19 5/8" W x 12 1/2" D, (11 3/8" usable depth space)
- Accessory shelf weight capacity: 25 lbs.

FP3500 Features:

- Includes all FP2000 features
- Additional VESA compliance of 500 x 800mm
- Unique tilt rotation feature, easily rotate from horizontal position to vertical position
- Accessory shelf: 19 5/8" W x 12 1/2" D, (11 3/8" usable depth space)
- Accessory shelf weight capacity: 25 lbs.



FP3500
With Accessory Shelf
& Rotating Mount

FP Series Measurements:

Camera mount settings:

1. 3"
2. 9"
3. 15"

Above the top of the poles.

* - Adjust in 2" increments, measured from the floor to the top of the poles.

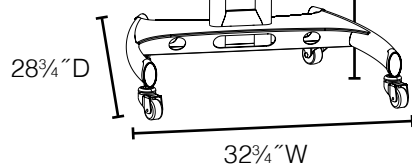

46 1/2" -
62 1/2" H*

Flat Panel TV Carts

Heavy Duty



WFP100-B
31½" W x 27¾" D x 61¼" H



61¼"

- This versatile flat panel stand holds a 32" - 60" flat panel TV
- Large footprint provides stability and prevents tipping
- Three plastic shelves 28½" W x 13½" D.
- Black steel tube frame with a built in push handle
- A set of 3" furniture casters, two with locking brakes.
- Universal mounting bracket included

WPSMS51 Mobile Flat Panel Stand

- Includes a universal mount which holds a 37" - 60" flat panel or LCD TV
- Constructed of an all steel frame
- Four 4" lockable casters
- Single shelf for DVD player or other A/V equipment
- Stylish, curved metal legs.
- Integrated wire management
- Black powder coat paint finish.

***Height is the measurement from the floor to mount center**



18¾" x 11¾"

51"

WPSMS51
31" W x 28" D x 51" H

Flat Panel TV Carts

WPSMS Series



- Holds 37" to 60" flat panel TV's
- Two heavy duty chrome steel tubes with a black powder coated base and cable management slots
- Engineered for safety.
- Base plate's 27" x 23½" footprint prevents tipping and the 49 lbs. of counter weight provides the proper center of gravity
- A set of silent roll, 4" full swivel ball bearing casters, two with locking brakes
- Shelf is included for units ending in SCH-4, perfect for DVD player & A/V equipment. 19" x 15" available shelf space
- Includes a universal mount which holds a 37 - 50" flat panel or LCD TV

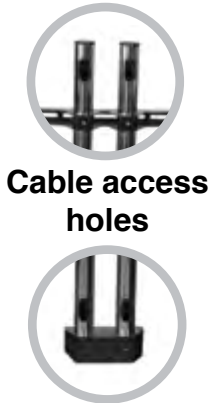

Cable access holes

Shelf Accessory
19" W x 15" D x 1¼" H

WPSMS62SCH-4
27" W x 23½" D x 65" H



WPSMS62CH-4
27" W x 23½" D x 65" H



WPSMS44SCH-4
27" W x 23½" D x 50" H



WPSMS44CH-4
27" W x 23½" D x 50" H

Flat Panel TV Carts

24x18

Adjustable Height



- Holds up to a 42" flat panel display
- Height adjusts from 44" - 62" in 2" increments
- Roll formed shelves with powder coat paint finish
- Available with drop leaf side shelves
- Cable pass through holes
- 3-outlet 15' UL and CSA listed electric
- ¼" Retaining lip around each shelf
- Steel locking cabinet with full piano hinge
- 4" ball-bearing casters, two with locking brake
- Inner cabinet dimensions: 20" W x 16¼" D x 14½" H

Color Options:



To specify which unit color is ordered, replace ★ in this example product number with available color option of choice:
AVJ42CDL-LCD★

AVJ42CDL-LCD-RD
 24"W x 18"D x 44-62"H



AVJ42C-LCD
 24"W x 18"D x 44-62"H



AVJ42-LCD-LG
 24"W x 18"D x 44-62"H



AVJ42DL-LCD-RB
 24"W x 18"D x 44-62"H



AVJ42-LCD
 24"W x 18"D x 44-62"H

Extra Large



AVJ42XL-LCD
32" W x 20" D x 44-62" H

AVJ42XL-LCD Features:

- Holds up to a 42" flat panel display
- Height adjusts from 44" - 62" in 2" increments (from the floor to the top of the poles)
- Roll formed shelves with powder coat paint finish
- Cable pass through holes
- 3-outlet 15' UL and CSA listed electric
- 1/4" retaining lip around each shelf
- Steel locking cabinet with full piano hinge
- 4" ball-bearing casters, two with locking brake

AV30XLC-LCD Features:

- 50" High (from the floor to the mount center)
- Inner cabinet dimensions: 32" W x 19 1/4" D x 23" H

NEW



AV30XLC-LCD
32" W x 20" D x 50" H



AVJ42XLC-LCD
32" W x 20" D x 44-62" H

E Series

Holds up to a 46" LCD TV
VESA up to 400 x 600

NEW



ET38E-B
32"W x 18"D x 57½"H*



ET34E-B
32"W x 18"D x 54½"H*



ET25E-B
32"W x 18"D x 44½"H*



ET38CE-B
32"W x 18"D x 57½"H*



ET34CE-B
32"W x 18"D x 54½"H*



ET25CE-B
32"W x 18"D x 44½"H*

*Height is the measurement from the floor to mount center

WPTV Series

- Shelves are constructed with an injection molded thermoplastic resin that will not chip, warp, rust or peel
- Includes a 3-outlet UL listed electrical assembly with a 15 ft. cord
- Electrical assembly is recessed to insure easy passage through doorways and other tight spots
- Includes silent roll, 4" full swivel ball bearing casters, two with locking brakes
- Locking steel cabinet panels fit firmly into the specially fluted leg slots
- Includes a universal mount with 15 degrees (+ or -) of tilt
- E Series Includes a new extruded aluminum LCD Mount



WPTV50E

Holds up to a
46" LCD TV
VESA up to
800 x 600



WPTV44CE



WPTV44E

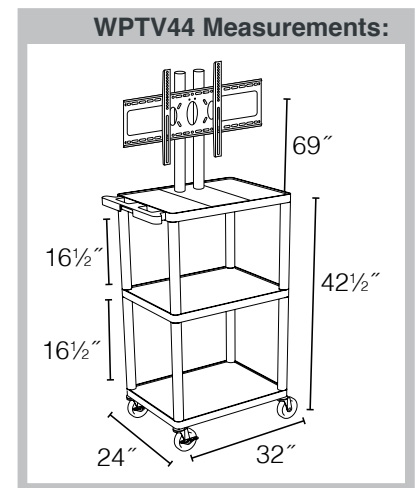

WPTV28CE



WPTV28E

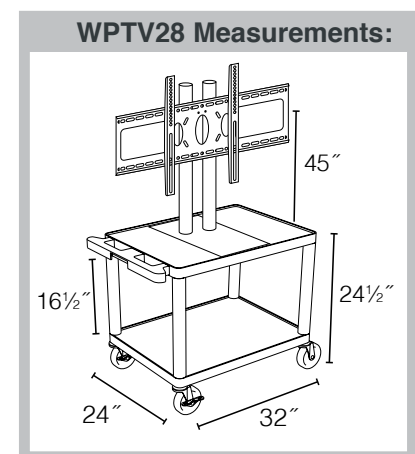

***Height is the measurement from the floor to mount center**

LEWTUD Series

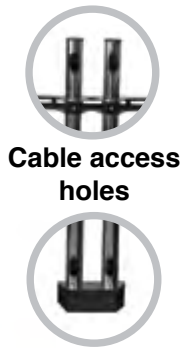

Cable access holes

- Shelves and legs are constructed with an injection molded thermoplastic resin
- Steel locking cabinet with full piano hinge
- Universal mount holds up to 50" screen
- 3-outlet, 15' surge suppressing electric assembly, UL and CSA listed
- Retaining lip around all shelves
- 4" Casters, two with locking brake

***Height is the measurement from the floor to the top of the poles**

LE27CWTUD-B
42" W x 24" D x 57½" H*



LE27WTUD-B
42" W x 24" D x 57½" H*

Two Shelf Measurements:

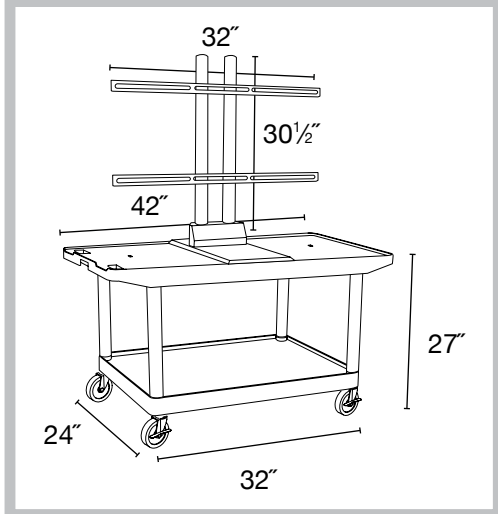

LEWTUD Series

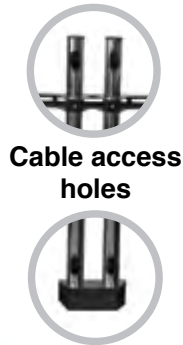

Cable access holes

- Shelves and legs are constructed with an injection molded thermoplastic resin
- Steel locking cabinet with full piano hinge
- Universal mount holds up to 50" screen
- 3-outlet, surge suppressing 15' electric assembly, UL and CSA listed
- Retaining lip around all shelves
- 4" Casters, two with locking brake

***Height is the measurement from the floor to the top of the poles**

LE40CWTUD-B
42" W x 24" D x 70 3/4" H*

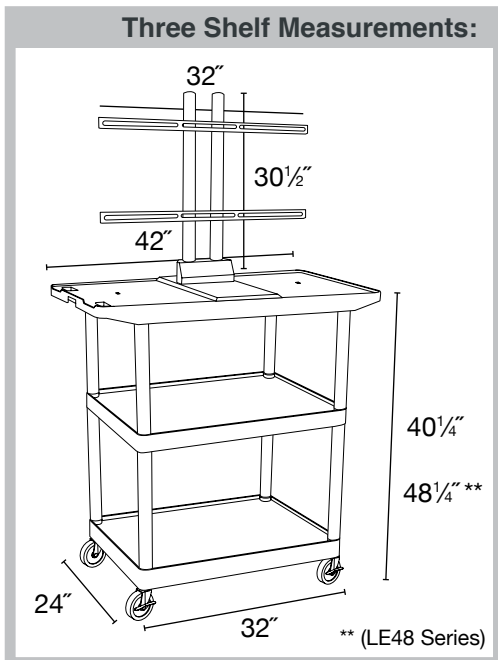

LE48WTUD-B
42" W x 24" D x 78 3/4" H*

Charging Carts

Tablet / Chromebook



LLTM30-B

26" W x 20 1/4" D x 36 3/4" H
Weight: 89 lbs.

Min/Max Tablet / Chromebook:

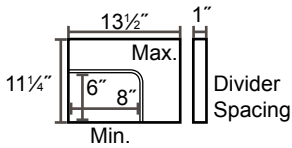

Rear access door has a 10' long, 16 outlet power cord on each side for LLTM30-B and LLTM30-B-RFID (on one side for LLTM16-B)



LLTM16-B + LLTM30-B Features:

- Unit comes fully assembled - just put on the casters and handle
- The rack shelves are 18 1/2" W x 13 1/2" D. Each shelf holds up to 15 tablets. Has 11 1/4" H of top clearance.
- Non-slip padded work surface on top of unit.
- The top inner shelf is 20 1/2" W x 11" D
- The padded shelves and rubber-coated dividers keep your tablets organized and protected
- Includes vertical electrical outlets for maximized space.
- Plenty of ventilation allows air to circulate freely through the unit.
- Includes four 4" casters, two with locking brakes.
- The locking doors include a traditional lock and key system, Includes a set of two keys.

LLTM42-B Features:

- The top inner shelf is 28 3/8" W x 11 1/8" D. Has 4 1/4" of top clearance.
- The rack shelves are 26 3/8" W x 13 1/2" D. Each shelf holds up to 21 tablets. Has 11 1/4" H of top clearance.



LLTM16-B

26" W x 20 1/4" D x 36 3/4" H
Weight 82 lbs.

Min/Max Tablet / Chromebook:

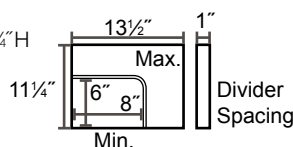

LLTM42-B

28 1/2" W x 22 1/4" D x 36 1/2" H
Weight 111 lbs.

Min/Max Tablet / Chromebook:

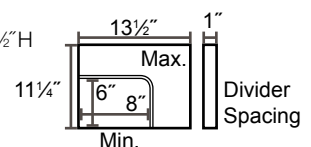

Charging Carts

Tablet / Chromebook



LLTM30-B-RFID

26"W x 20¼"D x 36¾"H

Weight: 88 lbs.

Min/Max Tablet / Chromebook:

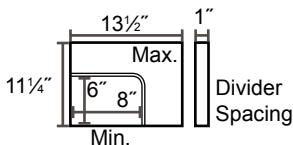

Easy access RFID card reader lock.



- The tablet charging shelves are 18½" W x 11¾" D
- Each shelf holds up to 15 tablets
- The padded shelves and rubber-coated dividers keep your tablets organized and protected
- Each divider is 1" apart
- Works with many different 125 KHz RFID inputs
- Includes two 10' long 16-Outlet vertical electrical strips
- The locking doors includes an easy to use high tech RFID locking system.
- Just swipe the card over the sensor to unlock. Four AA Batteries (not included) are required for each door to operate
- The lock features a low battery flash when you have less than 25 open cycles left. Two pre-programmed RFID cards are included, with the ability to program up to 30 cards if needed.



Accessory: Extra RFID Cards (30)
Available for purchase separately.



Accessory: Battery Pack
Available for purchase separately.
The battery pack allows you to power the unit from the outside to replace batteries on a locked unit. Batteries not included.

NEW

Tablets Not Included

Wall / Desk Charging Box



- Unit comes fully assembled
- Holds up to 12 Tablets
- Perfect for Wall-mounted applications as well as desk surface configurations
- The inside is padded and the dividers are rubber-coated to keep your devices protected

LLTMW12-G

19"W x 13"D x 14"H

Weight 16 lbs.

Min/Max Tablet:

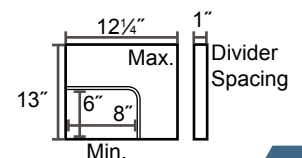

Charging Carts

Laptop / Chromebook



LLTP18-B

25" W x 21 1/8" D x 39 3/4" H

Weight: 84 lbs.

Min/Max Laptop / Chromebook:

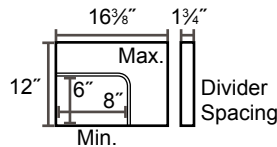

LLTP18-B Features:

- The LLTP18-B is the perfect solution to charging and securing up to 18 chromebooks / tablets.
- Unit comes fully assembled - just put on the casters and handle.
- The rack shelves are 20" W x 16" D. Each shelf holds up to 9 chromebook / laptops (12" H of top clearance).
- Each rubber-coated divider is 1 1/4" apart to keep your equipment organized and protected.
- Bottom shelf space is perfect for storing accessories and equipment (4 1/2" H of top clearance).
- Includes electrical outlets. Electrical cords can remain powered through two cord pass-through holes.
- Plenty of ventilation allows air to circulate freely through the unit.
- Includes four 4" casters, two with locking brakes.
- The locking doors include a traditional lock and key system, Includes a set of two keys.

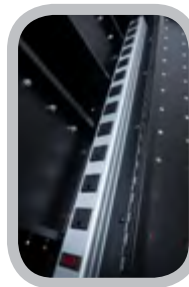

Rear access door has a 10' long, 9 outlet power cord on each side for LLTP18-B and 12 outlets on each side for the LLTP24-B.

NEW



LLTP24-B

31 1/8" W x 21 1/8" D x 40 1/8" H

Weight: 100 lbs.

Min/Max Laptop / Chromebook:

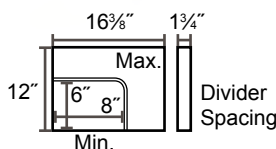

LLTP24-B Features:

- Includes LLTP18-B Features plus holds 24 chromebooks
- The rack shelves are 26" W x 16" D. Each shelf holds up to 12 chromebook / laptops (12" H of top clearance).
- Includes two 4" stationary casters and two full-swivel ball-bearing locking casters.



Chromebooks Not Included

Laptop / Chromebook



LLTP12-B
 14"W x 24³/₄" D x 39⁵/₈" H
 Weight: 66¹/₂ lbs.
Min/Max Laptop / Chromebook:

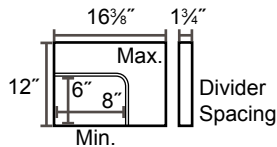

NEW

LLTP12-B Features:

- The LLTP12-B is a sleek and mobile charging unit for up to 12 chromebooks / tablets.
- Unit comes fully assembled - just put on the casters and handle.
- The rack shelves are 13³/₄" W x 16" D. Each shelf holds up to 6 chromebook / laptops (12" H of top clearance).
- Each rubber-coated divider is 1³/₄" apart to keep your equipment organized and protected.
- Bottom shelf space is perfect for storing accessories and equipment (4¹/₂" H of top clearance).
- Rear access door includes a 12 outlet electrical assembly. Electrical cord can remain powered through a cord pass-through hole.
- Plenty of ventilation allows air to circulate freely through the unit.
- Includes four 3" casters, two with locking brakes.
- The locking doors include a traditional lock and key system, Includes a set of two keys.

LLTS24-B Features:

- Includes 7 adjustable height wide shelves for storing up to 3 chromebooks per shelf for a total device count of 24 (including bottom shelf)
- The locking doors include a traditional lock and key system, Includes a set of two keys
- Rear access door has 24 outlets
- Has wide, nonskid top surface for supplies and equipment
- Ventilation holes in all panels allows heat from charging to dissipate
- Front and rear access
- 5" ball bearing casters, two with brake
- Assembly required.
- Shelves are adjustable with a maximum of 3" between each shelf



LLTS24-B
 43¹/₂" W x 20¹/₂" D x 40³/₄" H
 Weight: 164 lbs.

Presentation Stations

Adjustable Height



Also available with
Dark Walnut Shelves

PS3945-W

PS3945
24"W x 31"D x 39"-45"H

- Adjusts in height from 39" to 45" in height
- Top shelf is 24" W x 18" D
- Middle shelf is 24" W x 14" D
- Bottom shelf is 18 $\frac{3}{4}$ " W x 15 $\frac{3}{4}$ " D
- Perfect for desktop or chromebook
- Available in dark gray or dark walnut wood laminate work surfaces
- Black powder coat painted steel frame
- 3" casters, two with locking brake

Shelf Finish:	Dark Gray	Dark Walnut
----------------------	-----------	-------------



WPS3

18 $\frac{1}{4}$ " W x 29 $\frac{1}{2}$ " D x 42 $\frac{3}{8}$ " - 48" H

- Top shelf can be mounted either facing forward or back
- Middle shelf adjusts from 31 $\frac{1}{8}$ " - 38 $\frac{1}{8}$ " High
- Includes a set of silent roll, 3" furniture casters, two with locking brakes



WPSDA

31" W x 14 $\frac{1}{2}$ " D x 32 $\frac{1}{2}$ " - 41" H

- Platforms each tilt 45° and both work surfaces are independently adjustable in height
- Suited for seated or standing use
- Retaining lip on the bottom edge ($\frac{1}{4}$ ")
- Includes a set of silent roll, 3" furniture casters, two with locking brakes

Presentation Stations

PS4000 Series



Also available with
Dark Walnut Panels

PS4000C-W

PS4000C
18"W x 30"D x 40¼"H

- Four laminate work surfaces with steel frame
- Second shelf from the top is adjustable in height to 33", 37" or 40¼"
- Available in dark gray or dark walnut
- 3" Casters, two with locking brake
- PS4000C includes locking cabinet with interior dimensions of 13½" W x 18¾" H

Shelf
Finish:

Dark
Gray

Dark
Walnut



Also available with
Dark Gray Panels

PS4000

PS4000-W
18"W x 30"D x 40¼"H

PS4000 Measurements:

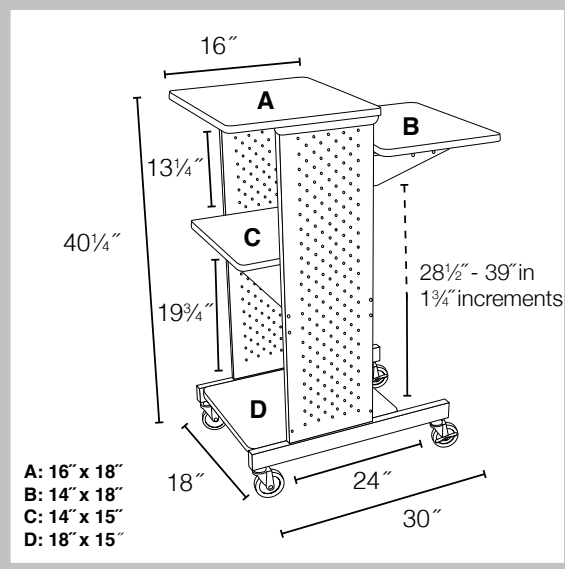

A: 16" x 18"
B: 14" x 18"
C: 14" x 15"
D: 18" x 15"

Presentation Stations

WPS4 Series



Shown with electrical assembly

WPS4CE
18 $\frac{1}{4}$ "W x 34 $\frac{1}{2}$ "D x 40"H

- Four laminate work surfaces with a steel frame
- Second shelf can be set from 32" up to 40" high
- Locking wood laminate cabinet model inner dimensions are: 18 $\frac{3}{4}$ " H x 13 $\frac{3}{4}$ " W x 13 $\frac{3}{4}$ " D
- Optional 3-outlet UL approved electrical assembly with 15 ft. cord
- A set of heavy duty 3" full swivel furniture casters, two with locking brakes

Shelf Finish: Gray

Steel Finish: Black

Measurements:

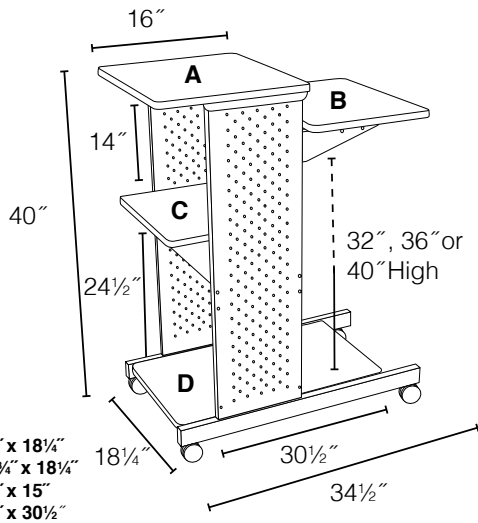

Shown with electrical assembly

WPS4E
18 $\frac{1}{4}$ "W x 34 $\frac{1}{2}$ "D x 40"H

Presentation Stations

WPS4HD Series



Shown with electrical assembly

WPS4CE-CB
18¼" W x 34½" D x 41" H

- Four wood looking laminate work surfaces with a steel frame
- Adjustable second shelf can be set from 33" up to 41" high
- Locking wood laminate cabinet model inner dimensions are: 18¾" H x 13¾" W x 13¾" D
- Optional a 3-outlet UL approved electrical assembly with 15 ft. cord
- A set of heavy duty 4" full swivel ball bearing casters, two with locking brakes

	HD	AS	CB
Shelf Finish:	Gray	Aspen	Black Cherry
Steel Finish:	Black	Nickel	Black

To specify which unit color is ordered, replace ★ in this example product number with available color option of choice:

WPS4CE-★

Measurements:

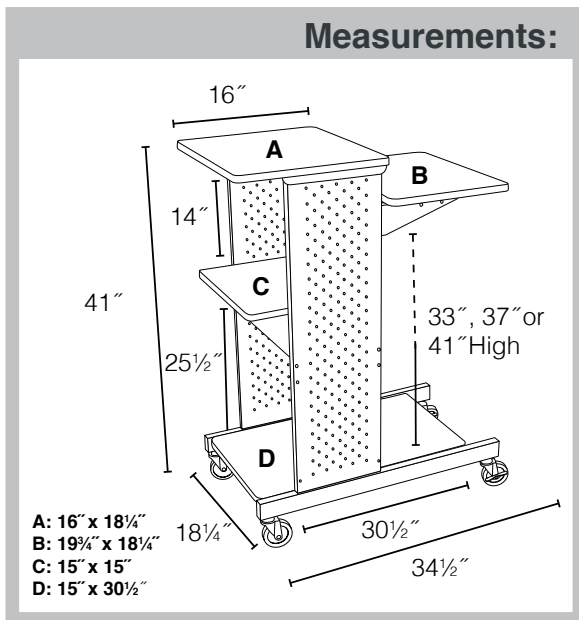

Shown with electrical assembly

WPS4E-AS
18¼" W x 34½" D x 41" H

Presentation Stations

Wood



WPSDD3



- Easy glide chromebook shelf, two flip up side shelves
- Cabinet, includes an adjustable, or removable inner shelf
- Constructed from a combination of durable metal and black / gray laminate finish.
- Four silent roll, 3" furniture casters, two with locking brakes.
- The Top shelf has a rounded corner for safety.

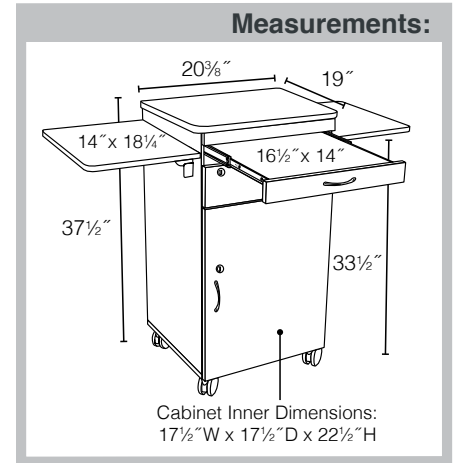

Steel

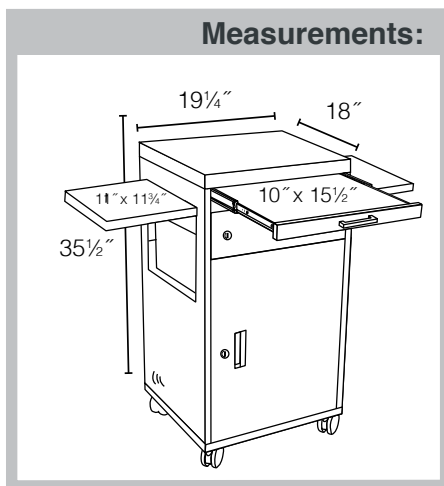

- All metal construction ships fully assembled, just put on the casters
- Black painted steel Multi-media cart with locking cabinet and drawer
- Pullout chromebook shelf has a handle that rotates to sit flush when not in use
- Two flip up side shelves
- Adjustable height middle shelf inside cabinet
- Comes with 3" casters, two with locking brake
- Optional LMCE 3-outlet electric



LMC2-B

Presentation Stations

Multi-media



WTPSCE

- This Presentation station features 18" x 24" top shelf
- Textured surface with 1/4" safety retaining lip
- Cable management hole in middle shelf
- Locking steel cabinet panels fit firmly into the specially fluted leg slots
- Slide out projector platform with vertical clearance of 9 3/4" with locking door
- Lower cabinet has two 18" x 24" surfaces and two locking doors to provide access to A/V equipment
- Includes a 3-outlet UL listed electrical assembly with a 15 ft. cord & cord wrap
- Four silent roll, 4" full swivel ball bearing casters, two with locking brakes

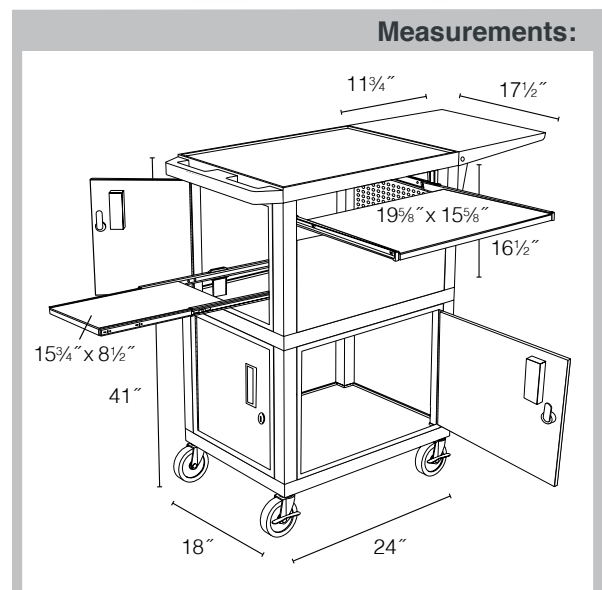

42" H Tuffy Series w/ Cabinet



WTPS42ZC4ME-N

With Cabinet

- Shelves and legs are constructed with an injection molded thermoplastic resin that will not chip, warp, rust or peel
- Shelves have a 1/4" safety retaining lip and are available in 12 unique colors
- Locking steel cabinet panels fit firmly into the specially fluted leg slots
- A set of silent roll, 4" full swivel ball bearing casters, two with locking brakes
- Includes a 3-outlet UL listed electrical assembly with a 15 ft. cord
- Optional pullout shelves, drawers and monitor mount

Shelf Colors:	Black	Gray GY	Red R	Burgundy BY	Blue BU
	Yellow Y	Orange OR	Hunter Green HG	Green G	Purple P
				Navy Z	

Cabinet Colors:	Nickel C4	Black C2
------------------------	---------------------	--------------------



WTPSLP42BYC2E-B



WTPS42HGC4E-N



WT42C2E-B/WD



WT42BUC4E-N

Presentation Stations

42" H Tuffy Series

Open Shelves

19 5/8" W x 13 5/8" D



WTPSLP42GYE-N

WT42 Series:

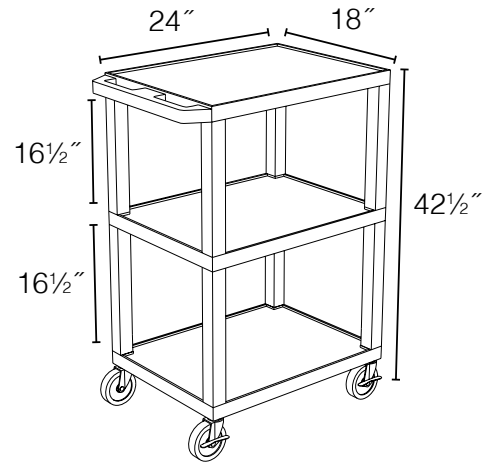

To specify which unit color is ordered, replace ★ in this example product number with available color option of choice:

WTPSLP42★E★

Leg
Colors:



WTPS42E-B



WT42BYE-N/WTD



WTPS42GME-B



WT42RE-N

Presentation Stations

24x18

42" H LP + LE Series w/ Cabinet



LP42CLPE-B

The 42" height and multiple pullout shelf / monitor mount options make the LP42 series the ultimate solution for standing presentations.

19 1/2" W x 13" D

- Shelves and legs are constructed with an injection molded thermoplastic resin
- Built in cord wrap in the handle
- Retaining lip around each shelf
- Steel locking cabinet with full piano hinge
- 4" ball bearing casters, two with locking brake

Also Available in LE Configuration which includes grip strips, wire clips, grommet hole and surge suppressing electric.

19 5/8" W x 13 5/8" D



LP42CLE-B



LP42CPE-B



LP42CE-B | LE42C



LPDUOCE | LEDUOC
24" W x 18" D x 26" - 42" H
includes multiple sets of legs to make a 26", 34" or 42" cart.

Presentation Stations

42" H LP + LE Series



LP42LE-B

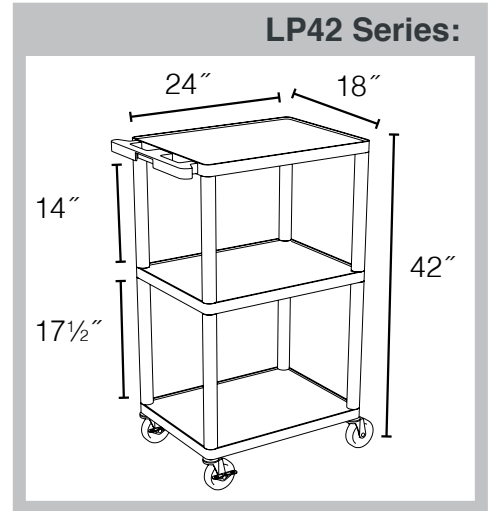

Also Available in LE Configuration which includes grip strips, wire clips, grommet hole and surge suppressing electric.



LP42LPE-B



LP42PE-B



LP42E-B | LE42



LPDUOE | LEDUO

24"W x 18"D x 16"-42"H
includes multiple sets of legs to make a 16", 26", 34" or 42" cart.

Presentation Stations

24x18

26" - 34" H Tuffy Series w/ Cabinet



19 1/2" W x 13" D

- Shelves and legs are constructed with an injection molded thermoplastic resin that will not chip, warp, rust or peel
- Shelves have a 1/4" safety retaining lip and are available in 12 unique colors
- Locking steel cabinet panels fit firmly into the specially fluted leg slots
- A set of silent roll, 4" full swivel ball bearing casters, two with locking brakes
- Includes a 3-outlet UL listed electrical assembly with a 15 ft. cord
- Optional pullout shelves and drawers

WTPS34ZC4E-N

Cabinet Colors:

Nickel C4	Black C2
--------------	-------------

Shelf Colors:

Black	Gray GY	Red R	Burgundy BY	Blue BU
Yellow Y	Orange OR	Hunter Green HG	Green G	Purple P
				Navy Z



WTPSP34BUC2E-B



WT34BYC4E-N



WT34GC2E-B/WTD



WT26C4E-N

Presentation Stations

26" - 34" H Tuffy Series



WTPS34ZE-N

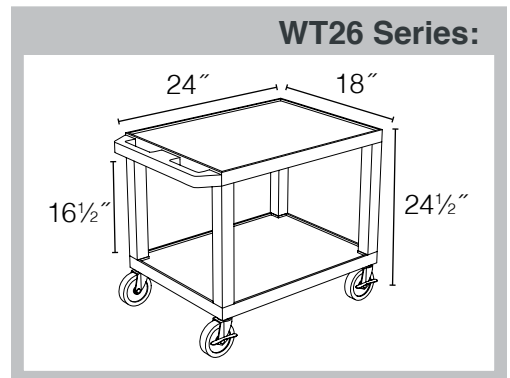
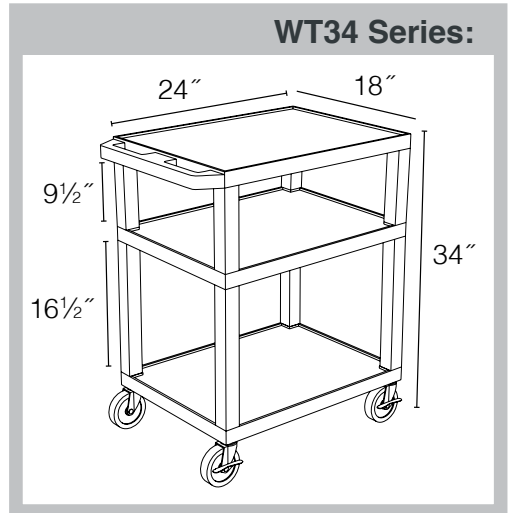

Leg
Colors:

Nickel -N	Black -B
--------------	-------------

To specify which unit color is ordered, replace ★ in this example product number with available color option of choice:

WTPS34★E★



WTSP34E-B



WT34BYE-N



WT34ZE-B/WTD



WT26GYE-N

Presentation Stations

24x18

26" - 34" H LP + LE Series w/ Cabinet

The multiple height and pullout shelf options make the LP / LE series the ultimate solution for standing presentations.



19 1/2" W x 13" D

- Shelves and legs are constructed with an injection molded thermoplastic resin
- Built in cord wrap in the handle
- Retaining lip around each shelf
- Steel locking cabinet with full piano hinge
- 3-Outlet electric assembly With 15' Cord, UL and CSA listed
- 4" ball bearing casters, two with locking brake

LP34CLE-B
24"W x 18"D x 35 1/2"H

Also Available in LE Configuration which includes grip strips, wire clips, grommet hole and surge suppressing electric.



LP34CPE-B
24"W x 18"D x 35 1/2"H



LP34CE-B | LE34C
24"W x 18"D x 35 1/2"H



LP26CE-B | LE26C
24"W x 18"D x 26"H

Presentation Stations

26" - 34" H LP + LE Series



LP34LE-B | LEMFP
24"W x 18"D x 35½"H

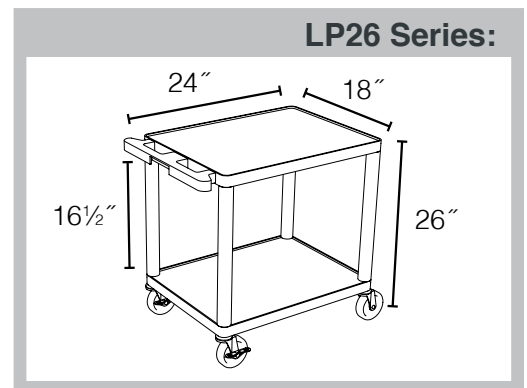
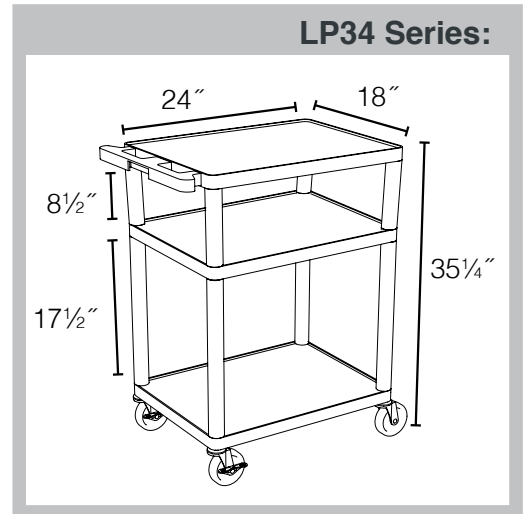

19 5/8"W x 15 5/8"D



LP34PE-B
24"W x 18"D x 35½"H



LP34E-B | LE34
24"W x 18"D x 35½"H



LP26E-B | LE26
24"W x 18"D x 26"H

Also Available in LE Configuration which includes grip strips, wire clips, grommet hole and surge suppressing electric.

Value Series



MPTL-B
24"W x 18"D x 38 $\frac{1}{4}$ "H

- Shelves and legs are constructed with an injection molded thermoplastic resin
- Built in cord wrap in the handle
- Retaining lip around each shelf
- Steel locking cabinet with full piano hinge
- 2" furniture casters, two with locking brake

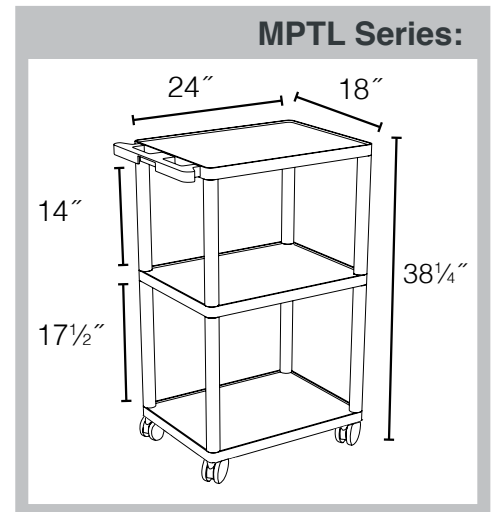

NEW

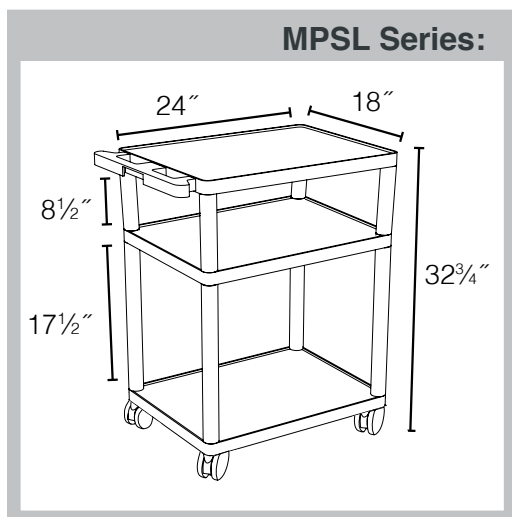

MPSL-B
24"W x 18"D x 32 $\frac{3}{4}$ "H

WTPS70 Series



WTPS71E

Shelf Colors: Gray Black

Leg / Cabinet Colors: Nickel Black

- Multiple shelves accept any combination of presentation equipment
- Locking steel cabinet panels fit firmly into the specially fluted leg slots
- Pullout shelf ideal for chromebook and keyboard
- Lockable WTD drawers great for storage and added security.
- A set of six heavy duty, 4" ball-bearing casters, three with locking brakes
- Includes a 3-outlet UL listed electrical assembly with a 15 ft. cord

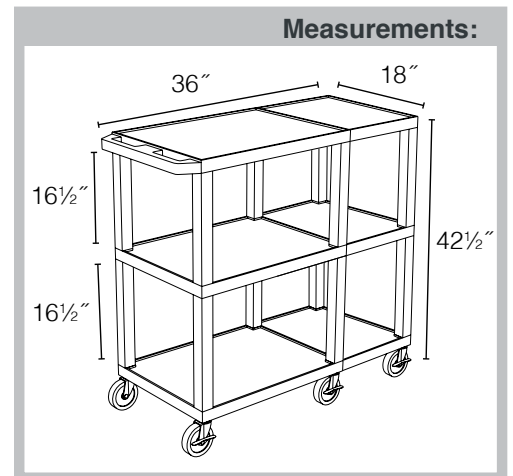

WTPS70E



WTPS73E



WTPS72E

Presentation Stations

32x18

EA Series



EA42E-B



EA42LE-B



EA42LME-B

- 32" W x 18" D flat shelves
- 33% More capacity than a standard 24" W x 18" D cart
- Has an ergonomic push handle molded into the top shelf
- Four 4" full swivel casters, two with locking brake
- Shelves & legs are constructed with an injection molded thermoplastic resin
- 300 lb. Weight capacity (evenly distributed)
- Available with drawer, pullout shelf and / or monitor mount
- Includes 3-outlet electric w/ 15 ft. cord and 3 wire clips
- Also available without electric

Measurements:

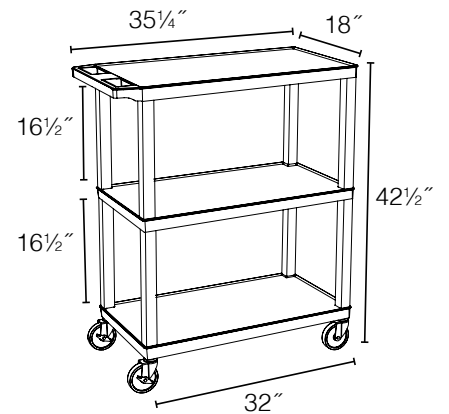

NEW



EA42CLME-B



EA42CLE-B



EA42CE-B

Presentation Stations

EA Series



EA34E-B



EA34DE-B



EA34LE-B

- 32" W x 18" D flat shelves
- 33% More capacity than a standard 24" W x 18" D cart
- Has an ergonomic push handle molded into the top shelf
- Four 4" full swivel casters, two with locking brake
- Shelves and legs are constructed with an injection molded thermoplastic resin
- 300 lb. Weight capacity (evenly distributed)
- Available with drawer, pullout shelf and / or monitor mount
- Includes 3-outlet electric w/ 15 ft. cord

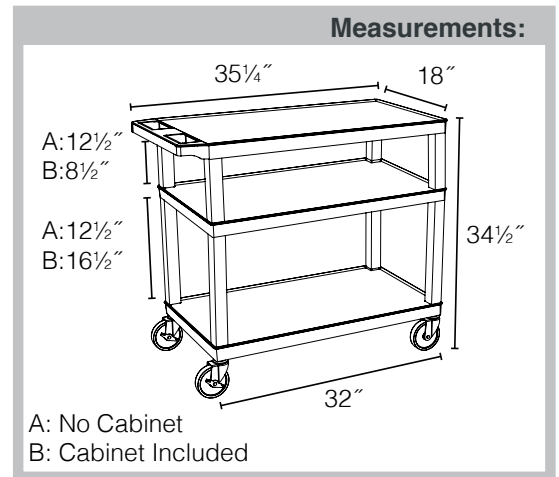

NEW



EA34CLE-B



EA34CDE-B



EA34CE-B

Extra Large



The large shelf size makes this LP series ideal for almost any presentation needs.

- Shelves and legs are constructed with an injection molded thermoplastic resin
- 2" diameter legs and 2" thick shelves perfect for heavy duty application
- Built in cord wrap in the handle
- Retaining lip around each shelf
- Steel locking cabinet with full piano hinge
- 4" ball bearing casters, two with locking brake
- Includes 3-Outlet electric assembly With 15' Cord, UL and CSA listed

LP40CLE

32"W x 24"D x 40¼"H

Also Available in LE Configuration which includes grip strips, wire clips, grommet hole and surge suppressing electric.



LP27CE | LE27C
32"W x 24"D x 27"H



LP40CE | LE40C
32"W x 24"D x 40¼"H



LP48CE | LE48C
32"W x 24"D x 48¼"H



LP54CE | LE54C
32"W x 24"D x 54¼"H

Presentation Stations

Extra Large



LP40LE
32"W x 24"D x 40¼"H

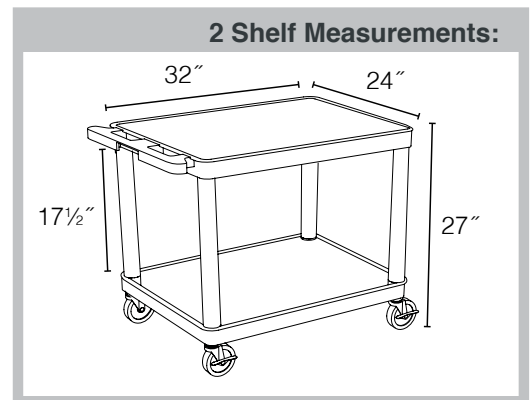
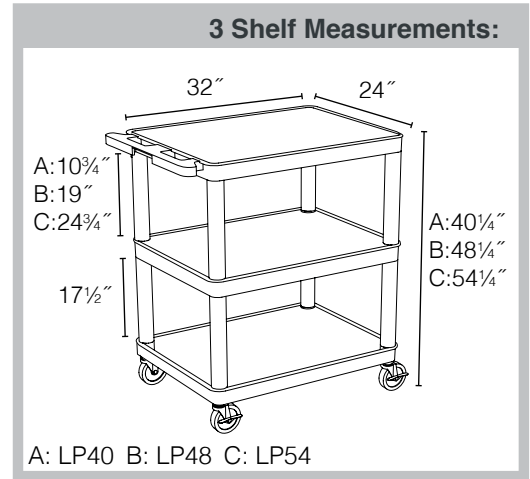

Also Available in LE Configuration which includes grip strips, wire clips, grommet hole and surge suppressing electric.



LP27E | LE27
32"W x 24"D x 27"H



LP40E | LE40
32"W x 24"D x 40¼"H



LP48E | LE48
32"W x 24"D x 48¼"H



LP54E | LE54
32"W x 24"D x 54¼"H

Presentation Stations

LT Series



LT45
24"W x 15³/₄"D x 44¹/₄"H



LT45C
24"W x 15³/₄"D x 44¹/₄"H

- Shelves and legs are constructed with an injection molded thermoplastic resin
- 3-outlet, surge suppressing 15' electric assembly, UL & CSA listed
- 300 Lb. weight capacity (evenly distributed between all shelves on three shelf models)
- Set of sure grip pads prevents equipment from sliding
- Steel locking cabinet with full piano hinge
- 4" ball-bearing casters, two with locking brake



LT342S
24"W x 15³/₄"D x 33¹/₂"H



LT34
24"W x 15³/₄"D x 33¹/₂"H



OHT32
24"W x 15³/₄"D x 33¹/₂"H

Workstations + Desks

Laminate / Steel



LCT29-G
24" W x 19" D x 29" H

Also available in



- Wood laminate work surface available in red, blue, gray and charcoal
- Steel frame with silver finish
- 2" Furniture casters, two with locking brake
- Pullout keyboard and mouse shelf



LAMC2936
31 1/2" W x 29" D x 29-36" H

- Adjusts in height from 29" to 36"
- Laminated teak finish
- 2" furniture casters
- Keyboard shelf measures 27" W x 12" D



LAMC3037
31 1/2" W x 29" D x 30-37" H

- Adjusts in height from 30" to 37"
- Base can be used as printer or CPU shelf
- Gray laminated finish
- 3" casters, two with locking brake
- Keyboard shelf measures 27" W x 12" D

Workstations + Desks

Stand Up Desks



STANDUP-40-B
39½" W x 29" D x 34½" - 46½" H

- Sturdy steel frame with powder coat silver paint finish
- Split level design makes the work surfaces perfect for any computer or chromebook configuration
- Durable laminate wood surface available in black (B) or dark walnut (DW)
- Adjusts in height by 1" increments
- Available in 3 different widths
- Easy to maneuver with 3" furniture casters 2 with locking brakes
- Includes all hardware and tools required for assembly
- Optional 3-outlet electrical assembly (51911)



STANDUP-31.5-DW
31½" W x 29" D x 34½" - 46½" H



STANDUP-24-B
24" W x 29" D x 34½" - 46½" H

	-B	-DW
Shelf Finish:	Black	Dark Walnut

NEW

Workstations + Desks

Stand Up Desks



STANDUP-40-DW
39½" W x 29" D x 34½" - 46½" H

Stand Up Desk Measurements:

Keyboard Shelf	Top Shelf	
28½"	1	34½"
29½"	2	35⅝"
30½"	3	36⅝"
31½"	4	37⅝"
32½"	5	38⅝"
33½"	6	39⅝"
34½"	7	40⅝"
35½"	8	41⅝"
36½"	9	42⅝"
37½"	10	43⅝"
38½"	11	44⅝"
39½"	12	45⅝"
40½"	13	46⅝"
	14	
	15	

Width Varies by Model

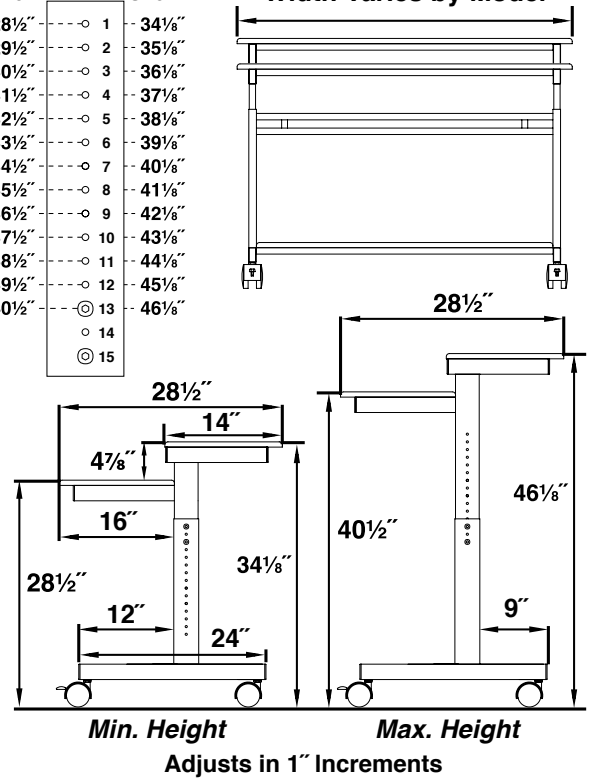

Min. Height **Max. Height**
Adjusts in 1" Increments



STANDUP-31.5-B
31½" W x 29" D x 34½" - 46½" H



STANDUP-24-DW
24" W x 29" D x 34½" - 46½" H

-B -DW
Shelf Finish: Black Dark Walnut

NEW

LEM Series



LEM32TTK-B
32"W x 24"D x 51½"H

- Shelves and legs are constructed with an injection molded thermoplastic resin
- Bottom shelf is shaped to accommodate seated use
- Surge suppressing 3-outlet electrical has a 15' cord
- Retaining lip around each shelf
- 4" ball bearing casters, two with locking brake
- 2" diameter legs and 2" thick shelves



**3-Outlet surge
suppressing electric
assembly with 15' cord**



LEM32K-B
32"W x 24"D x 27"H



LEM32TT-B
32"W x 24"D x 51½"H



LEM32-B
32"W x 24"D x 27"H

MD + WTM Series



MDL-B
24"W x 18"D x 33"H



MD-B
24"W x 18"D x 33"H



- Shelves are constructed with an injection molded thermoplastic resin that will not chip, warp, rust or peel
- Shelves have a 1/4" safety retaining lip. Available in black.
- Features a new easy-install metal pullout keyboard shelf.
- A set of 2" furniture casters, two with locking brakes.



WTM9E
24"W x 18"D x 33"H



WTM1E
24"W x 18"D x 33"H



WTM5E
24"W x 18"D x 41 1/2"H



WTM8E
24"W x 18"D x 54"H

- Includes a 3-outlet UL listed electrical assembly with a 15 ft. cord. Electrical assembly is recessed to pass through narrow spaces.
- A set of silent roll, 4" full swivel ball bearing casters, two with locking brakes.

Workstations + Desks

OHT Series



OHT42-B
32"W x 24"D x 37¼"H



OHT42PS-B
32"W x 24"D x 37¼"H

- Shelves and legs are constructed with an injection molded thermoplastic resin
- 3-Outlet, surge suppressing electric assembly With 15' Cord, UL and CSA listed
- Cabling hole in top shelf with cord guide cover, and "Cable track" cord management system
- Steel locking cabinet with full piano hinge
- 1/4" Retaining lip and sure grip safety pads prevent equipment from sliding
- 4" Ball bearing casters, two with locking brake
- 2" diameter legs and 2" thick shelves

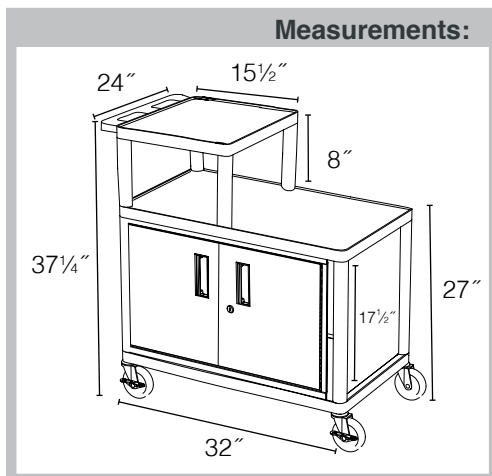

OHT42PSC-B
32"W x 24"D x 37¼"H

Book Trucks + Podiums

Laminate / Steel



PS3144
20"W x 16½"D x 33-47½"H

- Adjustable height lectern with gray laminate top and black frame
- Surface Area: 20" W x 16 ½" D
- Includes four adjustable glides



LX9128
23¼"W x 19¼"D x 36¼" - 45"H

- Complete with 2" casters, 2 with brake
- Top with retainer lip tilts to allow for flat work surface
- Adjusts in height from 36¼" - 45" tall



BT6S37-P
37"W x 18"D x 42"H

- All welded steel
- Quiet and easy rolling 4" ball bearing casters
- Available in black or putty
- 10½" Shelf clearance



BT3S27-B
27"W x 13"D x 42"H

- All shelves have a 10° tilt
- Model BT6S37 has 3 shelves on each side with a 6⅜" depth
- 3 Shelf units have a 9½" shelf depth



BT3S17-P
17"W x 13"D x 42"H

Serving Carts

Plastic / Wireframe



SC12-G
33 1/2"W x 16 3/4"D x 36 3/4"H

Shelf Color Options:	Black	Gray
	-B	-G



SC13-B
40 1/2"W x 19 3/4"D x 37 1/4"H

- 200 lb. capacity (evenly distributed)
- Each shelf is 26" W x 16 1/4" D
- Durable polypropylene shelves and aluminum uprights
- Dual handles for maximum control
- Four gray non-marring casters

- 300 lb. capacity (evenly distributed)
- Each shelf is 33 1/4" W x 19 3/4" D
- Durable polypropylene shelves and aluminum uprights
- Dual handles for maximum control
- Four gray non-marring casters

- One 3 1/2" deep tub shelf, two 1" deep tub shelves
- Four 3" casters, two with brake
- Tub shelves can be arranged in any order



LICWT2918
30"W x 18"D x 30"H



LICWT3014
24"W x 14"D x 32"H

Stainless Steel



SSC-3
28 1/4" W x 16" D x 34 1/4" H

- Type 201 stainless steel
- 16 gauge legs and 20 gauge shelves
- 300 pound weight capacity (evenly distributed)
- Non-marring 4" casters, two with locking brake
- 1" retaining lip around sides and back of top and middle shelf
- Equipped with rubber bumpers on legs opposite handle
- Packaged knock-down for economical shipping
- Easy to assemble with tools included



L100S3
26" W x 16" D x 35" H

- Shelves measure 26" W x 16" D
- 201 Stainless steel shelves
- Includes four 4" casters, two with locking brakes

NEW



SST2L
37 3/8" W x 19 1/4" D x 35 3/8" H



SST2S
33 1/4" W x 17 3/8" D x 35 3/8" H

- Two stainless steel tub shelves
- Tub shelves are 3 3/4" deep
- Includes four 4" non-marring casters, two with locking brake
- Available in two sizes



ST-3
33 1/2" W x 21" D x 37" H

- Type 201 stainless steel shelves
- Retaining lip around each shelf
- 4" casters, two with locking brake
- Wide enough for two bussing tubs
- 200 lb. weight capacity

Tuffy Series



WT50B
24"W x 18"D x 50"H

- Shelves are constructed with an injection molded thermoplastic resin that will not chip, warp, rust or peel
- Shelves have a 1/4" safety retaining lip and are available in black
- Locking steel cabinet panels fit firmly into the specially fluted leg slots
- A set of silent roll, 4" full swivel ball bearing casters, two with locking brakes
- Optional WTD locking steel drawer



WT26C2-B
24"W x 18"D x 26"H



WT42C2-B/WTD
24"W x 18"D x 42"H



WT42C2-B
24"W x 18"D x 42"H



WT34C2-B/WTD
24"W x 18"D x 34"H



WT34C2-B
24"W x 18"D x 34"H



EC38CD-B
32"W x 18"D x 37½"H

- 32" W x 18" D flat shelves
- 33% More capacity than a standard 24" W x 18" D cart
- Has an ergonomic push handle molded into the top shelf
- Four 4" full swivel casters, two with locking brake
- Available in black or gray
- Shelves and legs are constructed with an injection molded thermoplastic resin
- 300 lb. Weight capacity (evenly distributed)
- Available with drawer, pullout shelf, monitor mount

NEW



EC38C-B
32"W x 18"D x 37½"H



EC34CD-B
32"W x 18"D x 34½"H



EC34C-B
32"W x 18"D x 34½"H



EC25C-B
32"W x 18"D x 24½"H

Tub Shelves

NEW



EC122C-B
32" W x 18" D x 38½"

- 32" W x 18" D flat shelves
- 33% More capacity than a standard 24" W x 18" D cart
- Has an ergonomic push handle molded into the top shelf



EC12C-B
32" W x 18" D x 26½"

- Four 4" full swivel casters, two with locking brake
- Shelves and legs are constructed with an injection molded thermoplastic resin
- 300 lb. Weight capacity (evenly distributed)
- Inner Cabinet: 31¼" W x 17¼" D x 16½" H



TC122C-B
32" W x 24" D x 39½" H

- Shelves and legs are constructed with an injection molded thermoplastic resin
- Steel locking cabinet with piano hinge doors
- Inner Cabinet: 18" H x 31" W x 23" D
- Fluted legs for easy installation of cabinet inserts



TC12C-B
32" W x 24" D x 30" H

- Retaining lip around the back and sides of flat shelves
- Includes four heavy duty 5" casters, two with brakes
- Tub shelves are 2¾" deep



LTIMC-B
32" W x 24" D x 58" H

LTIM-B
32" W x 24" D x 58" H

- Shelves & legs are constructed with an injection molded thermoplastic resin
- 1/4" Retaining lip and textured surface prevents equipment from sliding
- Includes 3-outlet surge suppressing electric assembly with 15' cord
- Holds up to 400 lbs. of evenly distributed weight
- Steel locking cabinet with full piano hinge
- 4" casters, two with locking brake

3-Outlet surge suppressing electric assembly with 15' cord



LEW40C-B
48" W x 24" D x 38" H

- Shelves and legs are constructed with an injection molded thermoplastic resin
- 2" diameter legs and 2" thick shelves
- Includes 3-outlet surge suppressing electric assembly with 15' cord
- Holds up to 400 lbs. of evenly distributed weight
- Steel locking cabinet with full piano hinge
- 4" casters, two with locking brake



LEW29C-B
48" W x 24" D x 28 1/2" H

Automotive Carts

Tub Shelves



MS21-B
24" W x 18" D x 20" H

- Shelves and legs are constructed with an injection molded thermoplastic resin
- Tub bottom shelf is 2 3/4" deep and perfect for tool storage
- Removable seat cushion may be used as kneeling pad
- 24" W x 18" D x 20" H
- 4" Easy roll casters, two with locking brake
- 300 lbs. weight capacity (evenly distributed)

**MADE IN
USA**



LPT42-B
32" W x 24" D x 38 3/4" H



LPT44-B
32" W x 24" D x 49 3/4" H

- Shelves and legs are constructed with an injection molded thermoplastic resin
- 300 lb. weight capacity when evenly distributed throughout shelves
- 4" Ball bearing casters, two with locking brake
- Black shelves & legs are made from recycled material

**MADE IN
USA**

Automotive Carts

Tub Shelves



ATC332
22"W x 15½"D x 32"H

- Three adjustable height shelves constructed of blow-molded plastic with metal frame
- Complete with 3" heavy duty casters, two with locking brake
- Built-in divider tray section in each tub shelf
- Red color only
- Weight capacity 33 lbs. per shelf

- Shelves & legs constructed with injection molded thermoplastic resin
- Tub shelves are 3¼" Deep
- Legs are large 2" diameter
- 400 lb. weight capacity when evenly distributed throughout shelves
- Four 4" ball bearing casters, two with locking brake
- Optional tray divider sets (6 removable trays each) and a locking lid (top shelf).



MTC30/N-B
24"W x 15¾"D x 33¼"H

**MADE IN
USA**



MTCLL (locking lid) and MTCL (non-locking lid) available for LPT and MTC units.



MTC30DLL/N-B
24"W x 15¾"D x 33¼"H

Janitorial Carts

Laundry and Cleaning Carts



HL14
38½" W x 24¾" D x 36½" H

HL14 has 1 section



HL15
38½" W x 24¾" D x 36½" H

HL15 has 3 sections

- Bag is constructed of heavy duty canvas and removes easily
- Chrome plated steel frame
- Load capacity: 7 bushels, 51 gallons, 100 lbs.
- Support bars under bag
- 2½" Gray non-marring casters, two with brake and 4 caster bumpers
- Outer dimensions: 38½" W x 24¾" D x 36½" H
- Inner dimensions: 30½" W x 19½" D x 23" H



HL13
25" W x 25" D x 36½" H

- Laundry cart folds for easy storage
- Comes complete with a yellow nylon laundry bag
- Blue frame color
- Features 3" gray non-marring casters



JCB30-B
32" W x 24" D x 48" H



JCB40-B
32" W x 24" D x 50" H



MSB42-B
32" W x 24" D x 42" H

- Heavy-duty polyethylene construction that will not chip, crack or rust
- Easy to clean, will not absorb odors
- Includes nylon trash bag (colors as shown)
- 8" big wheels and caster bumpers
- Stain resistant

**MADE IN
USA**

Plastic Utility Carts

Industrial / Storage

- Shelves and legs are constructed with an injection molded thermoplastic resin
- Will not chip, warp, rust or peel
- Shelves have a 1/4" safety retaining lip
- All include a set of silent roll, 4" full swivel ball bearing casters, two with locking brakes
- Has a maximum weight capacity of 300 lbs.



WT34S
24"W x 18"D x 34"H



WT42GYS
24"W x 18"D x 42"H

MADE IN USA

Shelf Color Options:

Black GY	Gray GY	Stone ST	Red R	Burgundy BY	Blue BU
Yellow Y	Orange OR	Hunter Green HG	Green G	Purple P	Navy Z



PPD300
30"W x 18"D x 5"H

- Heavy duty plastic dolly
- 3" Poly-swivel casters
- 1000 lb. weight capacity
- Non slip surface on each end

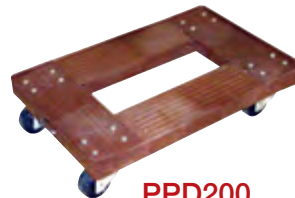

PPD200
24"W x 16"D x 5 1/2"H

- Heavy duty plastic dolly
- 3" Poly-swivel casters
- 800 lb. weight capacity



WT42BUNH-B
24"W x 18"D x 42 1/2"H



WT60RNH-B
24"W x 18"D x 60"H



WT78NH-B
24"W x 18"D x 78"H



SPD140
19"W x 29"D x 34"H

- Steel frame, non-skid vinyl deck
- 32 1/2" Handle folds for storage
- 4" Ball bearing casters, rear casters swivel

Shelf Color Options:

Black	Red R	Blue BU
--------------	-----------------	-------------------

MADE IN USA

Plastic Utility Carts

32x24

32" x 24" Shelves



TC11-G
32"W x 24"D x 37¼"H

- Shelves and legs are constructed with an injection molded thermoplastic resin
- Retaining lip around flat shelves
- Tub shelves are 2¾" deep, 2" diameter legs
- Push handle molded into the top shelf
- Optional 3-outlet electrical assembly
- Four 4" casters, two with locking brake
- 400 Lb. weight capacity (evenly distributed)

More shelf / leg color combinations available online.

**MADE IN
USA**



RDTC111RD
32"W x 24"D x 38"H



TC122-B
32"W x 24"D x 35"H



TC121-B
32"W x 24"D x 36½"H



TC112-G
32"W x 24"D x 36½"H



BUTC12BU
32"W x 24"D x 35¾"H

Plastic Utility Carts

32" x 24" Shelves

Shelf/Leg color choices:
Please specify color choice when ordering.
Carts come standard with matching leg.

Shelf / Leg
Color
Options:

Black B	Gray G	Red RD	Blue BU
-------------------	------------------	------------------	-------------------

To specify which unit color is ordered, replace
★ in this example product number with
available color option of choice: **TC111-★**



HE38-B
32"W x 24"D x 34½"H

**MADE IN
USA**



HE33-RD
32"W x 24"D x 33½"H



BUTC21BU
32"W x 24"D x 35½"H



TC221-G
32"W x 24"D x 35"H



BUTC211BU
32"W x 24"D x 36½"H



RDTC212RD
32"W x 24"D x 35"H

Plastic Utility Carts

32x18

32" x 18" Shelves



EC11-B
32" W x 18" D x 34 1/4" H

- 32" W x 18" D tub shelves are 2 1/2" in depth
- 33% More capacity than a standard 24" W x 18" D cart
- Has an ergonomic push handle molded into the top shelf, top flat shelf includes metal support bars
- Four 4" full swivel casters, two with locking brake
- Available in black or gray
- Shelves and legs are constructed with an injection molded thermoplastic resin
- 400 Lb. weight capacity (evenly distributed)
- Tub shelves are 3 1/2" H, flat shelves are 1 3/4" H

Also available with optional 5" heavy duty casters, two with swivel locking brake, two stationary. These casters will increase the over all weight capacity to 500 lbs. (evenly distributed) add "HD" to the model.



EC22-G
32" W x 18" D x 33" H



EC12-B
32" W x 18" D x 32 1/2" H



NEW

MADE IN USA

Measurements:

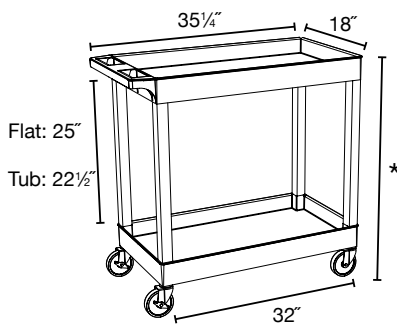

EC21-G
32" W x 18" D x 32 1/2" H



EC222-B
32" W x 18" D x 34 1/2" H

Plastic Utility Carts

32" x 18" Shelves



EC111-G
32"W x 18"D x 36¼"H

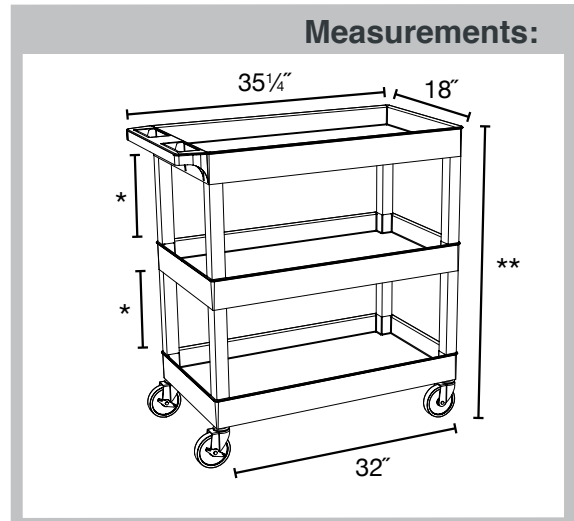

*- Above Tub= 10½" H
Above Flat= 12½" H

** - More Than Two Tub= 36¼" H
More Than Two Flat= 34½" H



EC112-B
32"W x 18"D x 36¼"H



EC121-G
32"W x 18"D x 36¼"H



EC211-B
32"W x 18"D x 36¼"H



EC221-G
32"W x 18"D x 34½"H



EC212-B
32"W x 18"D x 34½"H



EC122-G
32"W x 18"D x 34½"H

Plastic Utility Carts

24x18

24" x 18" Shelves



STC111-G
24"W x 18"D x 38½"H

- Shelves and legs are constructed with an injection molded thermoplastic resin
- Retaining lip around flat shelves
- Tub shelves are 2¾" deep
- Push handle molded into the top shelf
- Optional 3-outlet electrical assembly
- Four 4" casters, two with locking brake
- 300 Lb. capacity (evenly distributed)

Shelf/Leg color choices:
Please specify color choice when ordering.
Carts come standard with matching leg.

Shelf / Leg
Color
Options:

Black B	Gray G	Red RD	Blue BU
-------------------	------------------	------------------	-------------------

To specify which unit color is ordered, replace ★ in this example product number with available color option of choice: **STC111-★**



BUSTC122BU
24"W x 18"D x 36½"H



RDSTC121RD
24"W x 18"D x 36½"H



STC112-B
24"W x 18"D x 36½"H

Plastic Utility Carts

24" x 18" Shelves



HE34-G
24"W x 18"D x 32½"H

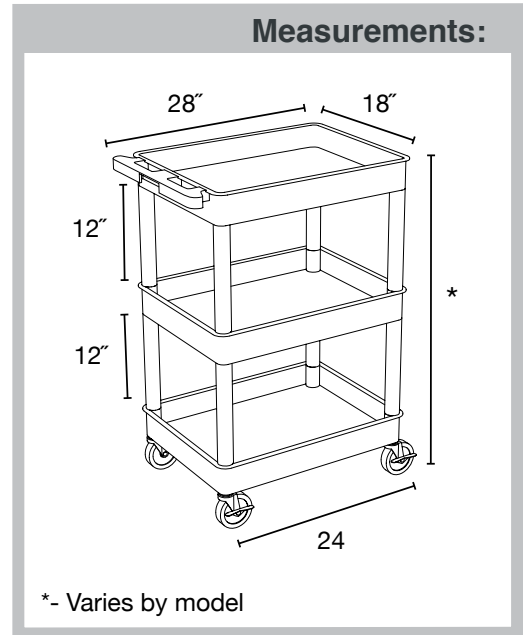

**MADE IN
USA**

More shelf / leg color combinations available online.



RDSTC221RD
24"W x 18"D x 34½"H



STC212-B
24"W x 18"D x 34½"H



BUSTC211BU
24"W x 18"D x 34½"H

Plastic Utility Carts

24x18

24" x 18" Shelves



37 1/2" H

STC11-G
24"W x 18"D x 37 1/2"H

- Shelves and legs are constructed with an injection molded thermoplastic resin
- Retaining lip around flat shelves
- Tub shelves are 2 3/4" deep
- Push handle molded into the top shelf / tub
- Optional 3-outlet electrical assembly
- Four 4" casters, two with locking brake
- 300 Lb. capacity (evenly distributed)

**MADE IN
USA**



34" H

STCS11-G
24"W x 18"D x 34"H



BUSTC12BU
24"W x 18"D x 35 1/2"H

NEW

Plastic Utility Carts

24" x 18" Shelves



HE32-B
24"W x 18"D x 33½"H

Shelf/Leg color choices:
Please specify color choice when ordering.
Carts come standard with matching leg.

Shelf / Leg Color Options:	Black B	Gray G	Red RD	Blue BU
----------------------------	-------------------	------------------	------------------	-------------------

To specify which unit color is ordered, replace ★ in this example product number with available color option of choice: **STC11-★**

More shelf / leg color combinations available online.

Measurements:

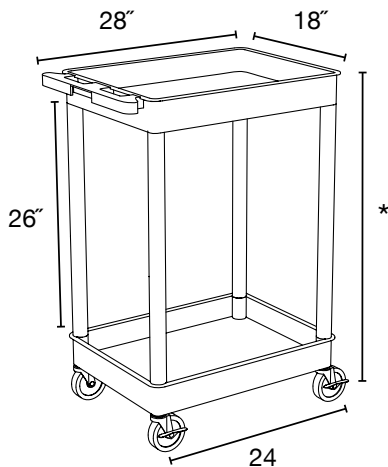

* - Varies by model



RDSTC21RD
24"W x 18"D x 35½"H

Steel Carts

Extra Large

32" W x 20" D x 24" - 42" H

18³/₄" x 11³/₄"



AVJ42XLC
W42XLC



AVJ42XL
W42XL



AVJ42XLKBC
W42XLKBC



AVJ42XLKKB
W42XLKKB

***Height is the measurement from the floor to mount center**

- Adjustable in heights from: 26" - 42"
- All steel shelves are 32" x 20" with a 1/4" retaining lip
- Steel shelves are welded for increased strength
- 3-Outlet UL listed electrical assembly with 15 ft. cord
- A set of silent roll, 4" full swivel ball bearing casters, two with locking brakes

MADE IN USA

Measurements:

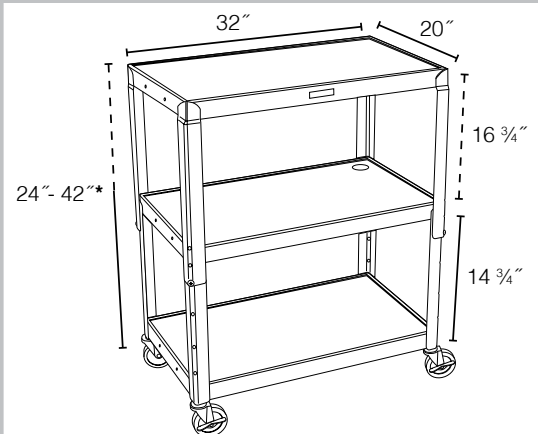

* - in 2" increments

- Available in four heights 26", 30 1/4", 34" and 42"
- 34" has one interior adjustable shelf, 42" has two shelves
- Locking security cabinet has full piano hinge doors
- 3-Outlet UL listed electrical assembly with 15 ft. cord
- A set of silent roll, 4" full swivel ball bearing casters, two with locking brakes



AV30XLC
32"W x 20"D x 30 1/4"H



MC29E
36"W x 24"D x 26"H



MC34E
24"W x 18"D x 34"H



MC42E
24"W x 18"D x 42"H



Adjustable Height

Available in 4 Colors:



AVJ42C
W42ACE

- Steel shelves have a 1/4" retaining lip, with cable access holes
- No slip rubber mat for adjustable top shelf
- Locking security cabinet has full piano hinge door
- A set of silent roll, 4" full swivel ball bearing casters, two with locking brakes
- Includes a 3-outlet UL listed electrical assembly with a 15 ft. cord

MADE IN USA

Color Options:

Black

Gray
-LG

Red
-RD

Blue
-RB

Measurements:

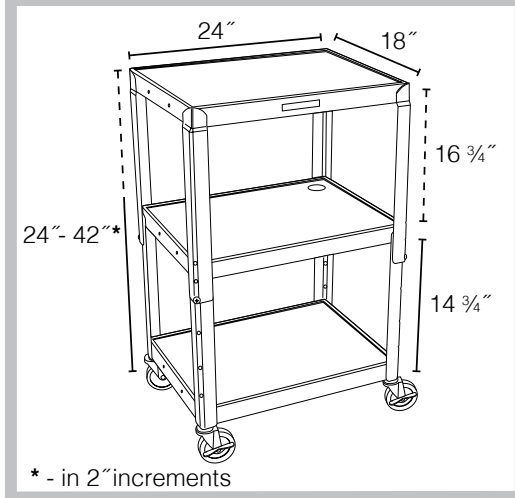

AVJ42-GN
W42AGE

Available in 8 Colors:



Color Options:

Black

Gray
-LG

Putty
-OW

Red
-RD

Blue
-RB

Yellow
-YW

Green
-GN

Navy
-Z

To specify which unit color is ordered, replace ★ in this example product number with available color option of choice: **AVJ42C★**

Steel Carts

24x18

Adjustable Height



Available in 4 Colors:

AVJ42KBC-RD
W42ARCEKB

- Steel shelves have a 1/4" retaining lip, with cable access holes
- No slip rubber mat for adjustable top shelf
- Locking security cabinet has full piano hinge door
- Pullout keyboard shelf which is ideal for chromebook & keyboards
- A set of silent roll, 4" full swivel ball bearing casters, two with locking brakes
- Includes a 3-outlet UL listed electrical assembly with a 15 ft. cord

Color Options:



MADE IN USA

Measurements:

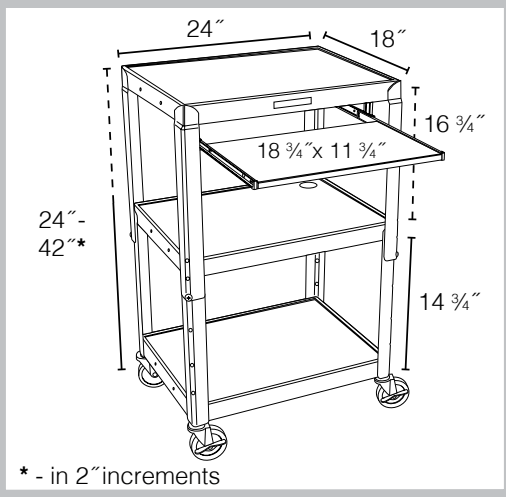

AVJ42KB-LG
W42AGYEKB

Available in 8 Colors:



Color Options:



To specify which unit color is ordered, replace ★ in this example product number with available color option of choice: **AVJ42KBC★**

Steel Carts

Adjustable Height



- Steel shelves have a $\frac{1}{4}$ " retaining lip, with cable access holes
- No slip rubber mat for adjustable top shelf
- Locking security cabinet has full piano hinge door
- Pullout keyboard shelf which is ideal for chromebook & keyboards
- Drop leaf side shelves add an additional work area and lock easily into position
- A set of silent roll, 4" full swivel ball bearing casters, two with locking brakes
- Includes a 3-outlet UL listed electrical assembly with a 15 ft. cord

Color Options:	Black	Gray -LG	Red -RD	Blue -RB
----------------	--------------	--------------------	-------------------	--------------------

Available in 4 Colors:

AVJ42KBCDL-RB
W42ABUCEKBDL

MADE IN USA

To specify which unit color is ordered, replace ★ in this example product number with available color option of choice:
AVJ42KBCDL★

Measurements:

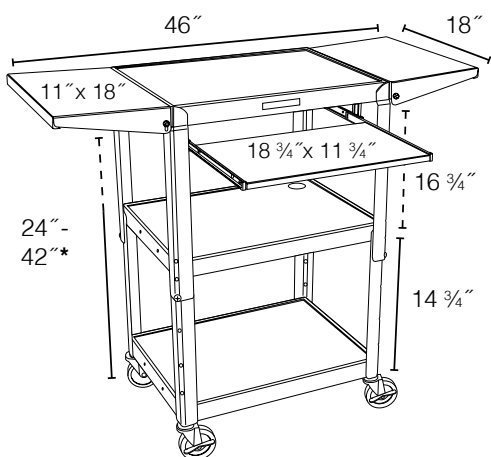

* - in 2" increments



Available in 5 Colors:

AVJ42KBDL
W42AEKBDL

Color Options:	Black	Gray -LG	Red -RD	Blue -RB	Navy -Z
----------------	--------------	--------------------	-------------------	--------------------	-------------------

Index

A		
ATC332	59	
AV30XLC	70	
AV30XLC-LCD	15	
AVJ42	71	
AVJ42C	71	
AVJ42CDL-LCD	14	
AVJ42C-LCD	14	
AVJ42DL-LCD	14	
AVJ42KB	72	
AVJ42KBC	72	
AVJ42KBCDL	73	
AVJ42KBDL	73	
AVJ42-LCD	14	
AVJ42XL	70	
AVJ42XLC	70	
AVJ42XLC-LCD	15	
AVJ42XLKB	70	
AVJ42XLKBC	70	
AVJ42XL-LCD	15	
B		
BM3040M	7	
BM3648M	7	
BT3S17	51	
BT3S27	51	
BT6S37	51	
BW3624M	6	
BW4030M	6	
BW4836M	6	
E		
EA34E-B	41	
EA34CE-B	41	
EA34CDE-B	41	
EA34CLE-B	41	
EA34DE-B	41	
EA34LE-B	41	
EA42E-B	40	
EA42CE-B	40	
EA42CLE-B	40	
EA42CLME-B	40	
EA42LE-B	40	
EA42LME-B	40	
EC11	64	
EC12	64	
EC12C-B	56	
EC21	64	
EC22	64	
EC25C-B	55	
EC34C-B	55	
EC34CD-B	55	
EC38C-B	55	
EC38CD-B	55	
EC111	65	
EC112	65	
EC121	65	
EC122	65	
EC122C-B	56	
EC211	65	
EC212	65	
EC221	65	
EC222	64	
ET25E-B	16	
ET25CE-B	16	
ET34E-B	16	
ET34CE-B	16	
ET38E-B	16	
ET38CE-B	16	
F		
FP2000	10	
FP2500	11	
FP2750	10	
FP3500	11	
H		
HE32	69	
HE33	63	
HE34	67	
HE38	63	
HL13	60	
HL14	60	
HL15	60	
J		
JCB30-B	60	
JCB40-B	60	
L		
L100S3	53	
L270	8	
LAMC2936	45	
LAMC3037	45	
LCT29	45	
LE26	37	
LE26C	36	
LE27	43	
LE27C	42	
LE27CWTUD-B	18	
LE27WTUD-B	18	
LE34	37	
LE34C	36	
LE40	43	
LE40C	42	
LE40CWTUD-B	19	
LE42	33	
LE42C	32	
LE48	43	
LE48C	42	
LE48WTUD-B	19	
LE54	43	
LE54C	42	
LEDUO	33	
LEDUOC	32	
LEM32-B	48	
LEM32K-B	48	
LEM32TT-B	48	
LEM32TTK-B	48	
LEMFP	37	
LEW29C-B	57	
LEW40C-B	57	
LICWT2918	52	
LICWT3014	52	
LLTM16-B	20	
LLTM30-B	20	
LLTM30-B-RFID	21	
LLTM42-B	20	
LLTMW12-G	21	
LLTP18-B	22	
LLTP24-B	22	
LLTP12-B	23	
LLTS24-B	23	
LMC2-B	28	
LP26CE-B	36	
LP26E-B	37	
LP27E	43	
LP27CE	42	
LP34CE-B	36	
LP34CLE-B	36	
LP34CPE-B	36	
LP34E-B	37	
LP34LE-B	37	
LP34PE-B	37	
LP40E	43	
LP40CE	42	
LP40CLE	42	
LP40LE	43	
LP42CE-B	32	
LP42CLE-B	32	
LP42CLPE-B	32	
LP42CPE-B	32	
LP42E-B	33	
LP42LE-B	33	
LP42LPE-B	33	
LP42PE-B	33	
LP48E	43	
LP48CE	42	
LP54E	43	
LP54CE	42	
LPDUOCE	32	
LPDUOE	33	
LPT42-B	58	
LPT44-B	58	
LT34	44	

LT45	44	STANDUP-40-B	46	WPSMS51	12
LT45C	44	STANDUP-40-DW	47	WPSMS62CH-4	13
LT342S	44	STC11	68	WPSMS62SCH-4	13
LTIM-B	57	STC12	68	WPTV28CE	17
LTIMC-B	57	STC21	69	WPTV28E	17
LX9128	51	STC111	66	WPTV44CE	17
M		STC112	66	WPTV44E	17
MB3040WW	8	STC121	66	WPTV50E	17
MB3624	8	STC211	67	WT26C2-B	54
MB3624WW	8	STC122	66	WT26C4E-N	34
MB3648WW	8	STC212	67	WT26E-N	35
MB4836	8	STC221	67	WT34C2-B	54
MB4836WW	8	STCS11	68	WT34C2-B/WTD	54
MB7240	8	T		WT34C4E-N	34
MB7240WW	8	TC11	62	WT34C2E-B/WTD	34
MC29E	70	TC12	62	WT34E-N	35
MC34E	70	TC12C-B	56	WT34E-B/WTD	35
MC42E	70	TC21	63	WT34S	61
MD-B	49	TC111	62	WT42C2-B	54
MDL-B	49	TC112	62	WT42C2-B/WTD	54
MGB3040	5	TC121	62	WT42C2E-B/WTD	30
MGB4836	5	TC122	62	WT42C4E-N	30
MPSL-B	38	TC122C-B	56	WT42E-N/WTD	31
MPTL-B	38	TC211	63	WT42E-N	31
MS21-B	58	TC212	63	WT42NH	61
MSB42-B	60	TC221	63	WT42S	61
MTC30DLL/N-B	59	W		WT50B	54
MTC30/N-B	59	W42ACE	71	WT60NH	61
O		W42ACEKB	72	WT78NH	61
OHT32	44	W42ACEKBDL	73	WTM1E	49
OHT42-B	50	W42AE	71	WTM5E	49
OHT42PS-B	50	W42AEKB	72	WTM8E	49
OHT42PSC-B	50	W42AEKBDL	73	WTM9E	49
P		W42XL	70	WTPS34C4E-N	34
PB3040W	8	W42XLC	70	WTPS34E-N	35
PPD200	61	W42XLKB	70	WTPS42C4ME-N	30
PPD300	61	W42XLKBC	70	WTPS42C4E-N	30
PS3144	51	WB3624W	9	WTPS42E-B	31
PS3945	24	WB4836W	9	WTPS42ME-B	31
PS4000C	25	WB7240W	9	WTPS70E	39
PS4000-W	25	WB9640W	9	WTPS71E	39
S		WFP100-B	12	WTPS72E	39
SC12	52	WGB4030	4	WTPS73E	39
SC13	52	WGB4836	4	WTPSCE	29
SPD140	61	WPS3	24	WTPSLP42C2E-B	30
SSC-3	53	WPS4CE-CB	27	WTPSLP42E-N	31
SST2L	53	WPS4E-AS	27	WTPSP34C2E-B	34
SST2S	53	WPS4CE	26	WTPSP34E-B	35
ST-3	53	WPS4E	26		
STANDUP-24-B	46	WPSDA	24		
STANDUP-24-DW	47	WPSDD3	28		
STANDUP-31.5-B	47	WPSMS44CH-4	13		
STANDUP-31.5-DW	46	WPSMS44SCH-4	13		



Presentation Stations

Marker Boards

Tablet / Chromebook Charging Carts

Stand Up Desks

Audio Visual Carts and Storage

Flat Panel TV Carts

Utility & Serving Carts



Scan this code on your mobile device or visit us at www.luxorfurn.com for the latest product information, high resolution images, instruction sheets and videos.

